



# HS-12-P Plastic Disposable 12"

## 12"x12"x12" Disposable Module

The HS-12 is made of incinerable plastic that comes in a set of two. The unit comes with your choice of granular filter media depending on the application.

### High Performance Features

- Designed to supply a large amount of filtration with low pressure drop
- Zero off gassing from adhesives
- Easy handling for maintenance and replacement

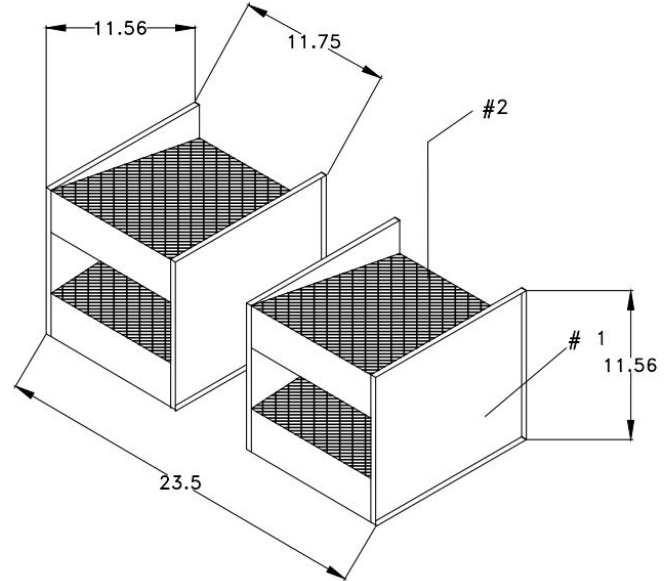

Common Media Used	Typical Applications
HS-AC	Restaurants, steel/alloy producers, refineries, casinos
HS-AC-P	New construction odors, VOCs, tobacco, ozone
HS-AC-P-KOH	Pulp & paper, sewerage treatment facilities, manufacturing & chemical processing
HS-600	Indoor air quality, low molecular weight, hydrocarbons, oxidizable acid gases, process odors
XB-17-P	Airports, pharmaceutical make-up air, funeral & nursing homes, animal care facilities, make-up air, heliports, museums
XB-17-P-KOH	Pulp & paper, sewerage treatment facilities, manufacturing & chemical processing and acidic sulfur gases
HS-Cannablend-Select	Cannabis Grow Houses: Vegetative, Flowering, Drying

Module Dimensions for Set (H x W x D)
12" x 24" x 12"

Contact Hydrosil for a custom filter.



125 Prairie Lake Rd,  
East Dundee, IL 60118

[sales@hydrosilintl.com](mailto:sales@hydrosilintl.com)  
[www.hydrosilintl.com](http://www.hydrosilintl.com)

1.847.844.0680  
1.800.PURPLE.1