

SPECIFICATIONS

16 GAUGE CONSTRUCTION
 RATE CAPACITY-500CFM
 .30 WG @250 FPM
 18 5/8 BEDS

WEIGHTS: +/- 5%

EMPTY: 30LBS

CARBON: 20LBS

HS-XB17 : 30 LBS

HS-600 : 35 LBS

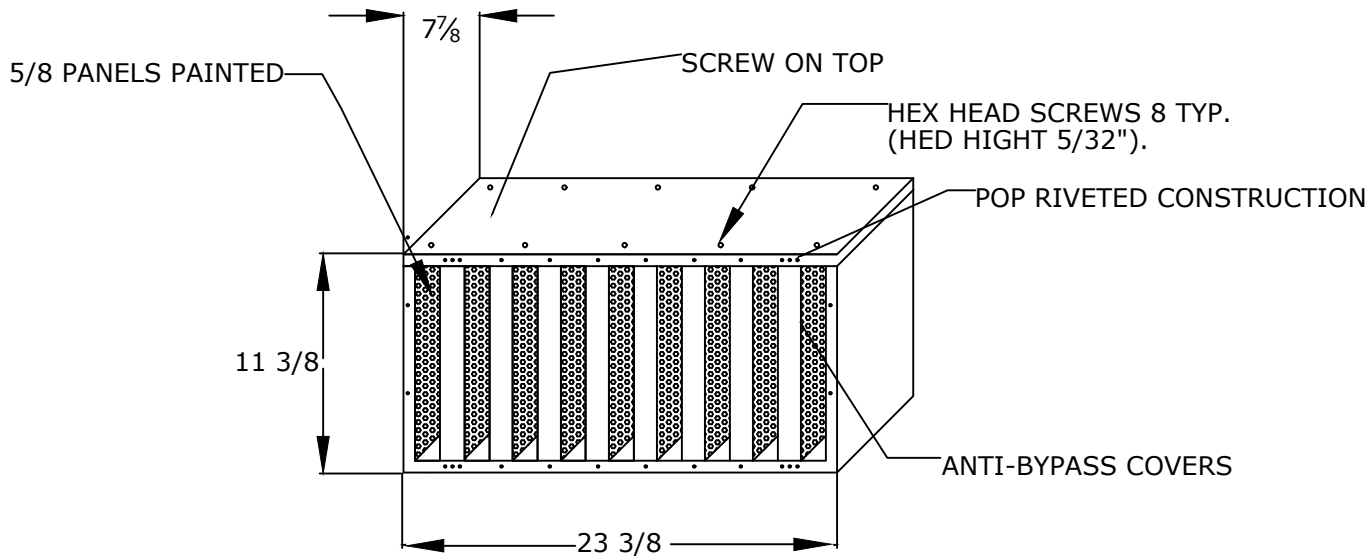
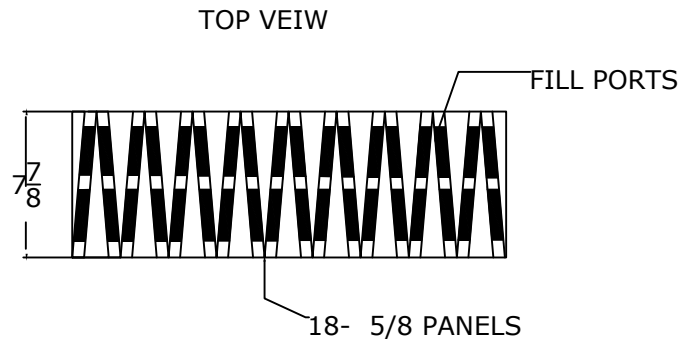

TITLE:

HS-ESMH

PART NO.

DRAWN: MLF

APPROVED:

DATE: 3/23/22

CHECKED:

CUSTOMER:

SCALE: N. T. S