

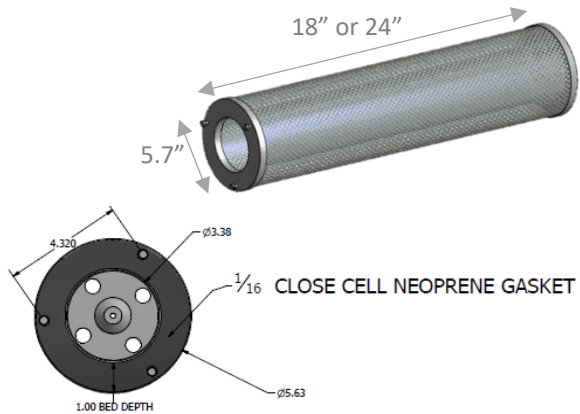

HYDROSIL CANISTER



Canister Model	Diameter & Length (inches)	Bed Depth (inches)	Nominal Resistance (inches w.g.)	Nominal Media Volume (cu. ft)
18	5.7 x 18	1.0	0.63	0.15
24	5.7 x 24	1.0	0.59	0.20

24 x 24 opening holds 16 cylinders at 2000 cfm

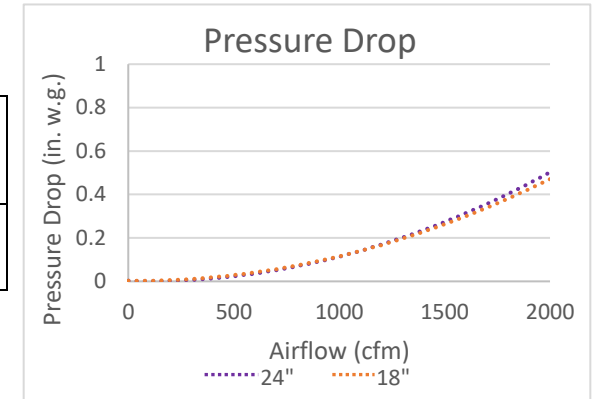

Media	Description	Typical Applications
HS-AC-P	Activated carbon	New construction odors, VOCs, tobacco, ozone
HS-AC-P-KOH	Impregnated carbon for corrosive & acid gases	Pulp & paper, sewerage treatment facilities, manufacturing & chemical processing
HS-600	Permanganate impregnated media	Indoor air quality, low molecular weight, hydrocarbons, oxidizable acid gases, process odors
XB-17-P	Blended HS-AC-P and HS-600	Airports, pharmaceutical make-up air, funeral & nursing homes, animal care facilities, make-up air, heliports, museums
XB-17-P-KOH	Permanganate impregnated media and other proprietary impregnations	Pulp & paper, sewerage treatment facilities, manufacturing & chemical processing and acidic sulfur gases
HS-Cannablend-Select	Specialty blends of activated carbon and impregnated media	Cannabis Grow Houses: Vegetative, Flowering, Drying and Cloning Rooms

