

SPECIFICATIONS

DIMENSIONS:

11 5/8" X 23 5/8" X 11 3/4"

18 GA END PLATES

.89" WG RESISTANCE AT 250 FT/MIN

BLACK POWDER COATED FINISH

V-BANK CONFIG

PERFORATED 22 GA

WEIGHTS:

EMPTY: 14 LBS

CARBON: APPROX. 30 LBS

50/50 BLEND: APPROX. 42 LBS

POTASSIUM: APPROX. 50 LBS

DUCT VELOCITY (FPM)	CFM PER 12 MODULE	PRESURE DROP (W.G.)
275	550	1.05
250	500	.89
200	400	.65
150	300	.40
100	200	.18
75	150	.12

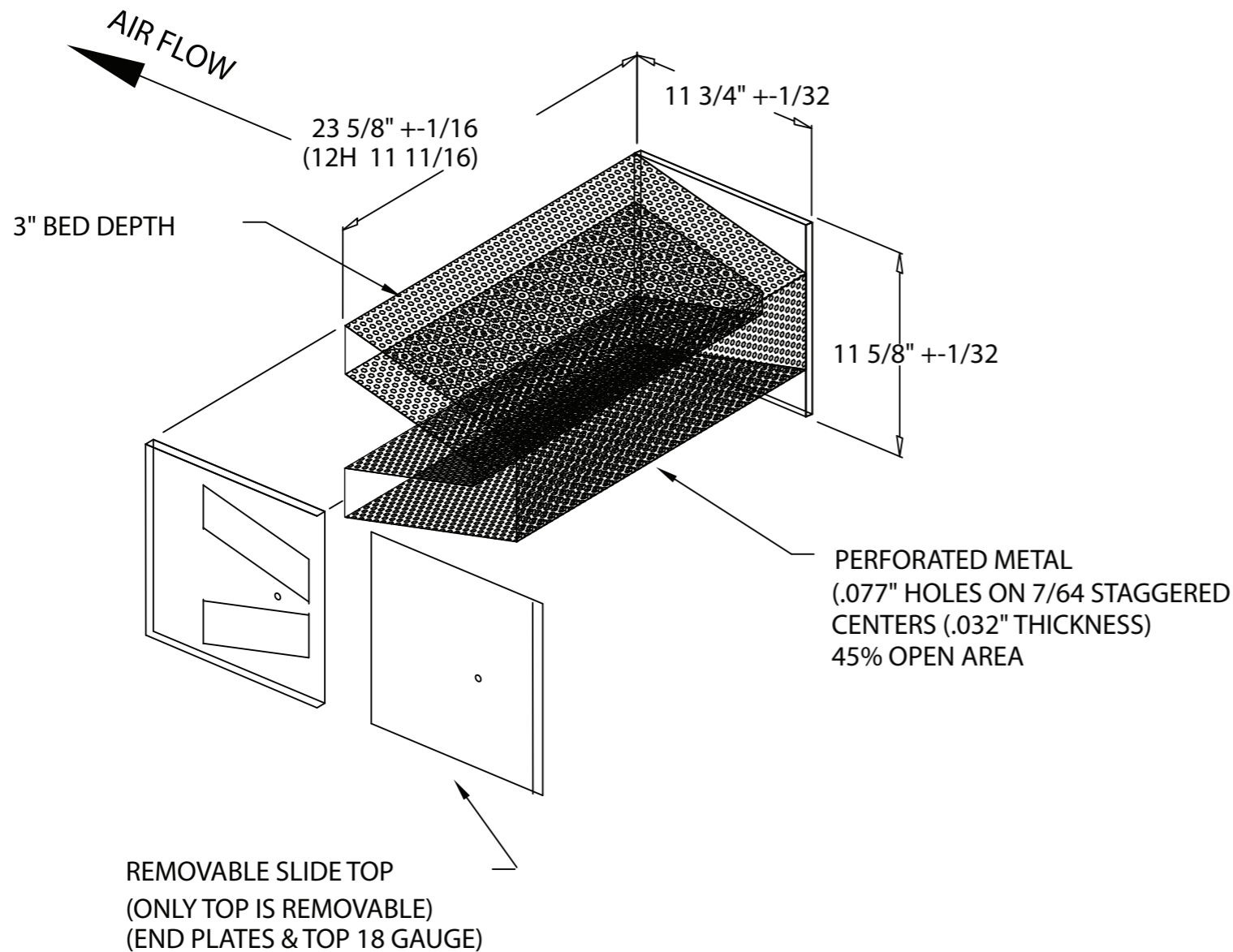

TITLE:

HS-12

SCALE: NONE	DWG NO.	
DRAWN: JJS	APPROVED:	DATE: 1/01/09
CHECKED:	CUSTOMER:	

HYDROSIL