

SPECIFICATIONS

DIMENSION

A= 51'
 B= 24'
 C= 30 3/4'

RECOMMENDED MAX AIR FLOW
 2000CFM PER SECTION

.50" WG RESISTANCE AT 500FT/MIN

90 LBS AC PER SECTION

16 GA. GALV.

10 PANELS V-BANK CON FIG PER SECTION

PANELS 23 11/16 X 23 11/16 X 1

PANELS 26 GA BLACK POWDER COATED

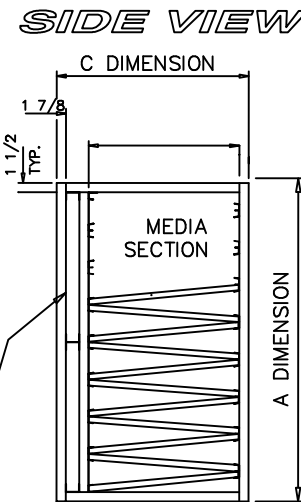
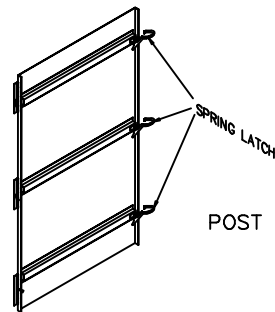
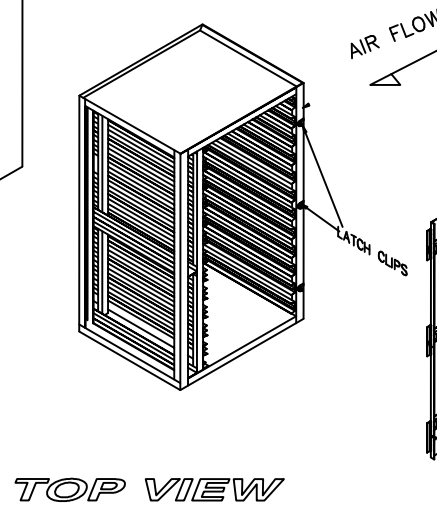
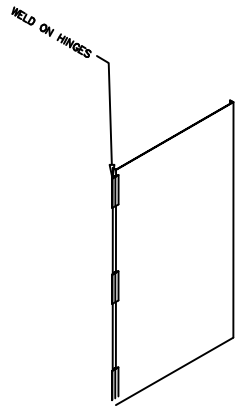
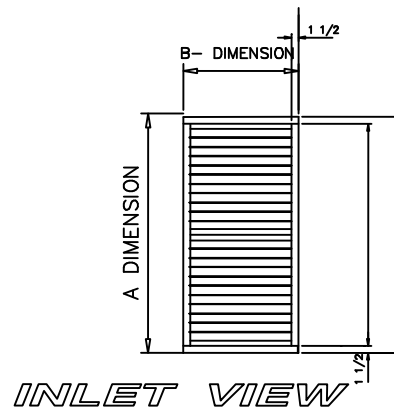

WEIGHTS:

EMPTY HOUSING: 200 LBS APROX.

CARBON: 180 LBS APROX.

50/50 BLEND:

POTASSIUM:

TITLE:

SAH 2X1 2P-1T

SCALE:	DWG NO.		
DRAWN: MLF	APPROVED:	DATE:	2/09/09
CHECKED:	CUSTOMER:		

HYDROSIL