

TOP VIEW

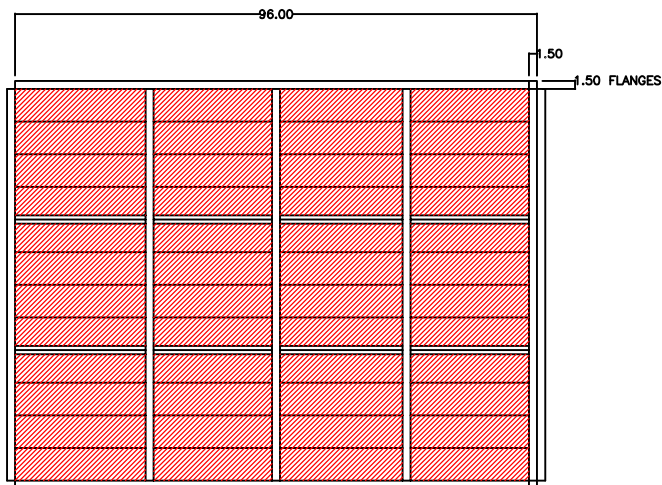

INLET VIEW

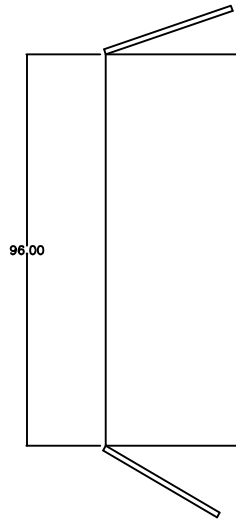
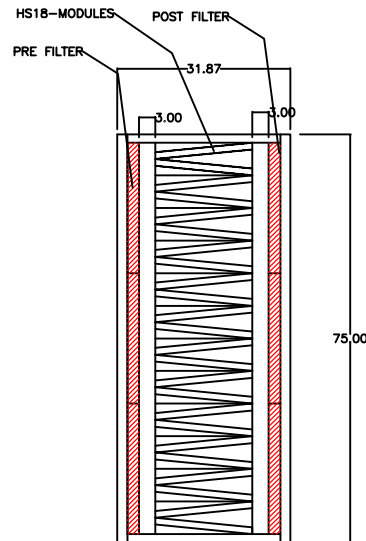

SIDE VIEW

SPECIFICATIONS

DIMENSIONS:

96W X 75H X 31 7/8" D

MADE FROM 16 GAUGE ALUMINIZED
ALL WELDED CONSTRUCTION

UNIT HOLDS

- 12 - 23 3/8 X 23 3/8 X 1 3/4
PRE FILTERS
- 48 - HS-18M MODULES
FILLED WITH XB-17
- 12 - 23 3/8 X 23 3/8 X 1 3/4
POST FILTERS

DOORS TWO SIDES
DOORS FULL GASKET FOR SEAL
SPRING LATCHES FOR POSITIVE SEAL
(OPTIONAL) DOUBLE WALL INSULATED

TITLE:

3X4 2P-18-2P

SCALE:	NONE	DWG NO.	
DRAWN:	MLF	APPROVED:	DATE: 3/16/09
CHECKED:		CUSTOMER:	

HYDROSIL