

TOP VIEW

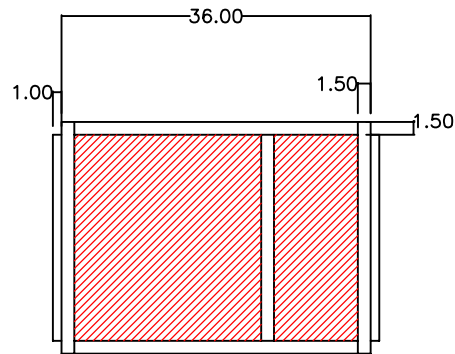

INLET VIEW

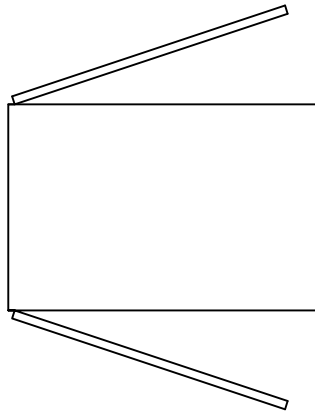
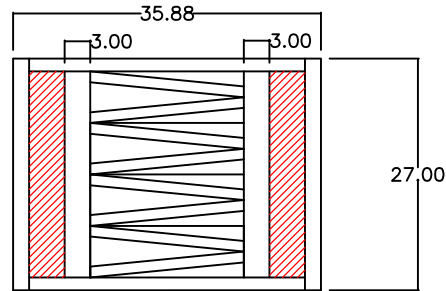

SIDE VIEW

SPECIFICATIONS

DIMENSIONS:

36W X 27H X 35 7/8D

MADE FROM 16 GAUGE ALUMINIZED
ALL WELDED CONSTRUCTION

UNIT HOLDS

1 - 23 3/8 X 23 3/8 X 3 3/4
PRE FILTERS

6 SETS - DP-18-P MODULES
FILLED WITH BLEND HS600/HSCL

1- 23 3/8 X 23 3/8 X 3 3/4
POST FILTERS

SIZED FOR 2500 CFM

DOORS TWO SIDES
DOORS FULL GASKET FOR SEAL
SPRING LATCHES FOR POSITIVE SEAL

TITLE:

1.5X1 4P-18DP-4P

SCALE:	N. T. S	DWG NO.	
DRAWN:	MLF	APPROVED:	DATE: 9/28/09
CHECKED:		CUSTOMER:	

HYDROSIL