

AIR FLOW

(4 SPRING CLIPS REMOVE GRID EASILY)

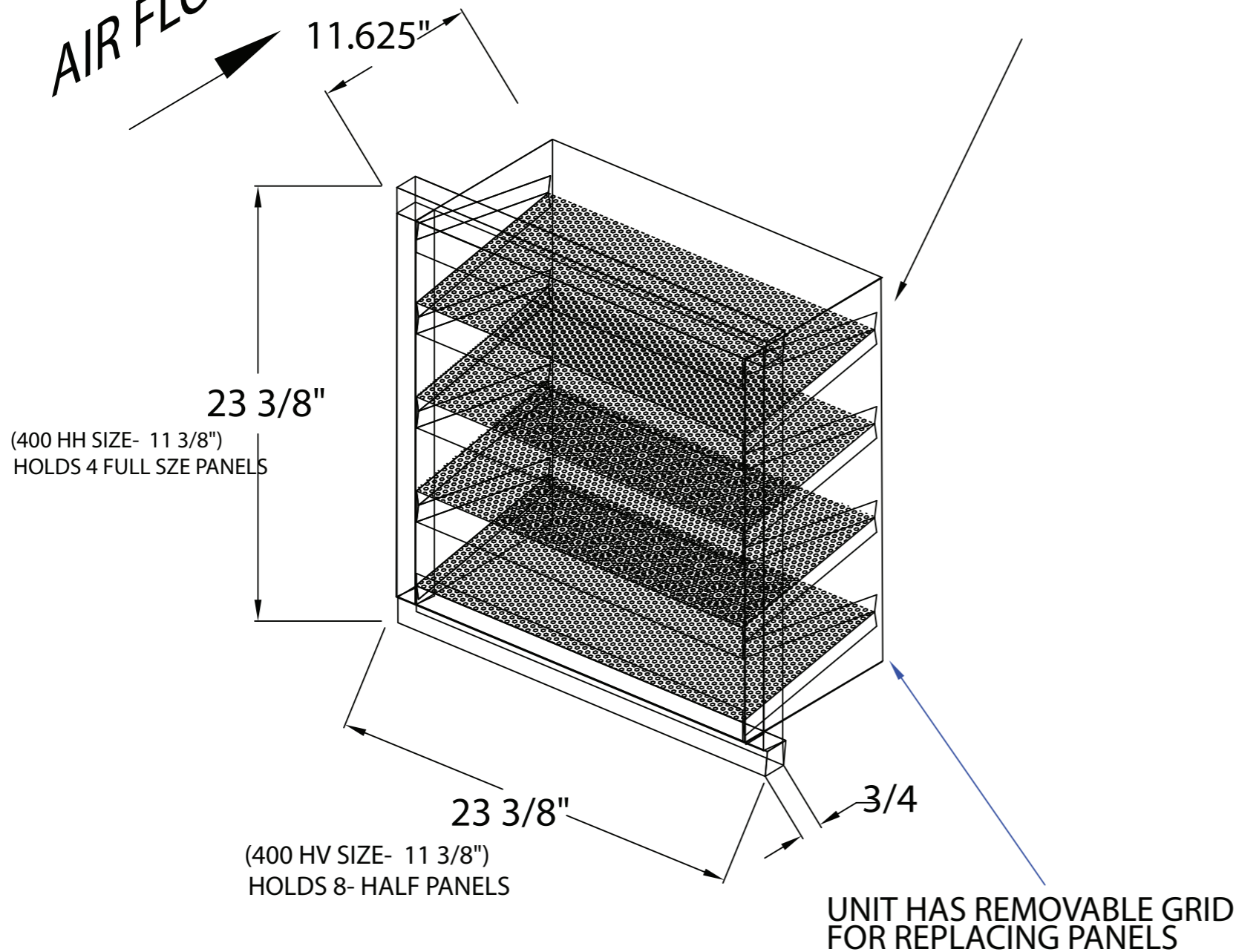

SPECIFICATIONS

DIMENSIONS:

FULL SIZE: 23 3/8 x 23 3/8 x 11 5/8

HALF SIZE: 11 3/8 x 23 3/8 x 11 5/8

STATIC PRESSURE DROP

DISPOSABLE--- 0.485" @ 2000CFM

REFILLABLE--- 0.77" @ 2000 CFM

18 GA. ALUMINIZED CASE

8 PANELS--10 7/8 X 21 5/8 X 1

HALF SIZE:

8 PANELS--10 7/8 X 9 5/8 X 1

PANELS DISPOSABLE OR REFILLABLE

WEIGHTS:FULL SIZE

EMPTY: 30 LBS

CARBON:

ZELITE INPREG:

CARBON / ZELITE INPREG

	DISPOSABLE	REFILLABLE
CARBON:	22LB	31LB
ZELITE INPREG:	50.5LB	62LB
CARBON / ZELITE INPREG	35.5LB	45LB

WEIGHTS:HALF SIZE

EMPTY: 25 LBS

CARBON:

ZELITE INPREG:

CARBON / ZELITE INPREG

	DISPOSABLE	REFILLABLE
CARBON:	9.5LB	14LB
ZELITE INPREG:	21.5LB	27.6LB
CARBON / ZELITE INPREG	16LB	20.5LB

TITLE:

400

SCALE: NONE

DWG NO.

DRAWN: JJS

APPROVED:

DATE: 01/01/09

CHECKED:

CUSTOMER:

HYDROSIL