

SPECIFICATIONS

DIMENSIONS: +/- 1/16

24 X 24 1/16 X 20

*2000CFM FRONT ACCESS UNIT W/PRE-FILTER AREA

*HOUSING: 16GA. CRS W/ BLACK POWDER COATING

REQUIRES 1 23 3/8 X SQ X 3 3/4 PRE FILTER

REQUIRES 4 SETS HS-18PH MODULES

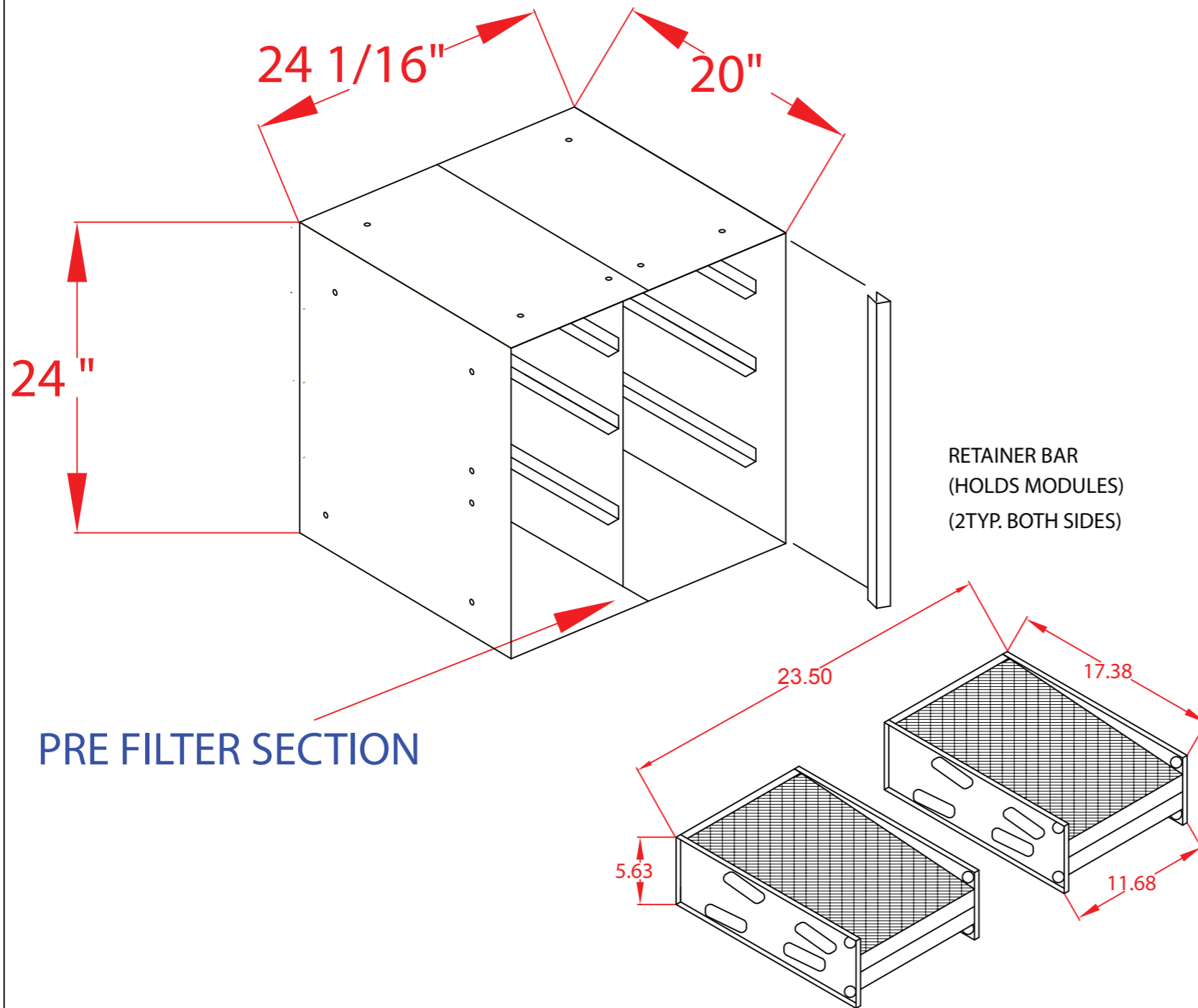

WEIGHTS

UNIT WITHOUT MODULES

44LBS

TITLE:

HS-22 SPLIT-2P

SCALE: NONE

DWG NO.

DRAWN: JJS

APPROVED:

DATE: 03/12/09

CHECKED:

CUSTOMER:

HYDROSIL